

PISA-BASED TEST FOR SCHOOLS SAMPLE TEST ITEMS

The OECD released a selection of sample test items from the assessment in an interactive, online format. The sample test items include questions at each proficiency level for each testing domain (reading, mathematics and science). These items were not used in the actual assessment, but they were used in the pilot of the assessment. This document contains the items used to populate the [sample test items website](#), which allows users to answer these PISA-based Test for Schools questions, discover their level of difficulty, and the concepts being tested.

QUESTION LEVEL 1: FREE**FREE! BUT AT WHAT PRICE?**

Imagine you are in a shop and you are offered a choice of two gift vouchers. Which one would you go for? Try to decide quickly!

- A £10 gift voucher for FREE!
- A £20 gift voucher for £7

If your first instinct is the same as absolutely everyone in a study carried out by Shampan'er and Ariely in 2006, you'll take the first option, the free option. Economically, though, this doesn't make any sense. When you look at it you can see that the £20 gift voucher is actually better value: you really get a £13 gift voucher for free. However, this is camouflaged by the way the offers are worded. The word "free" just shakes all rationality out of us.

Now compare these two offers and decide which you'd prefer:

- A £10 gift voucher for £1
- A £20 gift voucher for £8

Now if you're like the majority of people (64%) in Shampan'er and Ariely's study you'll go for the £20 gift voucher.

Notice that this time the price of each gift certificate has only been increased by £1. The £10 gift voucher has gone from £0 to £1 and the £20 gift voucher has gone from £7 to £8. Yet without the word 'free', most people suddenly realise that the £20 deal is superior, and decide to pay out for a better return.

So be aware of the seductive power that 'free' holds over your mind and you might decide you'd rather pay the price

QUESTION

According to the text, what effect does the word "free" have on consumers' ability to make decisions?

- A It prevents them from making decisions.
- B It slows down their decision-making.
- C It makes their decisions more thoughtful.
- D It makes their decisions less thoughtful.

**PRINT READING QUESTION (LEVEL 1)
THE CORRECT ANSWER IS:**

(D) – IT MAKES THEIR DECISIONS LESS THOUGHTFUL.

QUESTION LEVEL

Students at Proficiency Level 1 are capable of locating pieces of explicitly stated information that are rather prominent in the text, recognising a main idea in a text about a familiar topic, and recognising the connection between information in such a text and their everyday experience. Typically the required information in texts at this level is prominent and there is little, if any, competing information. The reader is explicitly directed to consider relevant factors in the task and in the text.

NATURE OF THE TASK

Draw inferences to identify the main idea in an exposition

The situation is *personal*. The question belongs to the *exposition* text type category because it is the type of text in which the information is presented as composite concepts or mental constructs, or those elements into which concepts or mental constructs can be analysed.

READING ASPECT

The aspect is *integrate and interpret – form a broad understanding* because the individual has to focus on relationships within the whole text.

SCORING

Full credit: D. It makes their decisions less thoughtful.

No credit: Other or missing.

QUESTION LEVEL 2: INDIAN MYSTIC**Indian Mystic Claims Not to Eat for 70 Years**

By Benamin Radford, LiveScience

An 82-year-old man in India is claiming to have not had anything to eat or drink since 1940 — and doctors from the Indian military are allegedly studying him to learn his secret.

The man, Prahlad Jani, is being observed in a Gujarat hospital. Jani claims to be a breatharian — someone who does not need to eat or drink, because he draws nourishment from the air and from meditation.

As remarkable as his story is, Jani is not the first, nor the only, person to claim such a supernatural power. The claim that people can live without food or water is called inedia, and is actually somewhat of a common claim among religious fakirs of India. Unfortunately, none of the cases have withstood scientific scrutiny. The human body needs both food and water to function; it's as simple as that.

It's easy for anyone to claim that he or she has not had anything to eat or drink for the past few weeks or months (or years). But unless the person has been carefully and continuously watched during that time, it's impossible to prove the assertion.

Several people who have claimed to survive without food or water were later caught eating and drinking. It can take only a few seconds to eat something, and other than in specific areas such as prisons, conducting a close around-the-clock surveillance on a person is not easy. Often the person will ask for privacy to sleep or go to the bathroom (which is suspicious in its own right) — and then snack surreptitiously. One well-known breatharian advocate in the 1980s, a man named Wiley Brooks, claimed he did not eat yet was caught consuming junk food.

This is not the first time that Jani has made this claim. He was examined in 2003 for about a week, during which time, he apparently did not eat or exercise — but he did lose weight. If Jani's abilities are real, it seems odd that he would lose weight during the time that his food intake was being monitored. If he truly gets all the sustenance he needs from air and meditation, there's no reason he would lose weight when he doesn't eat.

Reports claim that Prahlad Jani "has now spent six days without food or water under strict observation and doctors say his body has not yet shown any adverse effects from hunger or dehydration." Assuming the claim is true — and it's not clear just how strict the observation is — Jani's inedia so far remains unproven. If he really doesn't need food or water, he should be under close observation for months or years to prove it. Given that he claims not to have consumed anything since World War II, this shouldn't be a problem.

QUESTION

What is the author's attitude towards the idea that people can survive without food and water? Give a reason for your answer by using information from the article.

Type your answer here:

**PRINT READING QUESTION (LEVEL 2)
THE CORRECT ANSWER:**

REFERS TO THE IDEA THAT THE AUTHOR DOES NOT BELIEVE IN INEDIA AND PROVIDES EVIDENCE TO SUPPORT THIS.

QUESTION LEVEL

Students at Proficiency Level 2 are capable of tasks that require the reader to locate one or more pieces of information, which might need to be inferred and might need to meet several conditions. Other tasks at this level require recognising the main idea in a text, understanding relationships, or construing meaning within a limited part of the text when the information is not prominent and the reader must make low-level inferences. Tasks at this level may involve comparisons or contrasts based on a single feature in the text. Typical reflective tasks require readers to make a comparison or several connections between the text and outside knowledge, by drawing on personal experience and attitudes. PISA considers Level 2 a baseline level of proficiency at which students begin to demonstrate the reading skills and competencies that will allow them to participate effectively and productively in life as they continue their studies, and as they enter into the labour force and become members of society.

NATURE OF THE TASK

Identify an author's attitude in a persuasive text

The situation is *personal*. The question belongs to the *argumentation* text type category because it is the type of text that presents the relationship among concepts or propositions. Argument texts often answer why questions.

READING ASPECT

The aspect is *integrate and interpret – develop an interpretation* because the individual has to focus on relationships between parts of the text.

SCORING

Full credit: Refers to the idea that the author does not believe in inedia and provides evidence to support this. May quote directly from the text.

No credit: Gives an insufficient or vague response; shows inaccurate comprehension of the material or gives an implausible or irrelevant response; or missing.

QUESTION LEVEL 3: WRITING A TRAVEL ARTICLE

Let's say I want to write an article expressing my conviction that Croatia is the next big destination for travellers. First, I'd ask myself why I feel this way. Well, let's see: it's beautiful, it has a rich history, the people are warm and it's great value. I've isolated four salient points to support my theme, so the next question is order of importance.

To organise my story in terms of accelerating emotional connection, I'll lead with the point about value for money as it's the least emotional and most practical or logical consideration. History begins to involve the heart but is still fundamentally intellectual, so that would be second. Beauty is a more emotional consideration, drawing readers into the story via their soul. The people connection represents what I think is the climax of my trip, and the climax of travel itself, so that would come last. My final point is the top of the pyramid, but every step along the way contributes to my story's overall resonance and effectiveness.

Next, I'll search through my notes and draw out the experiences that brought these points to life. The hostel in Dubrovnik that cost just £15 a night, or that extraordinary meal under the stars that was £5. That's where I learned how inexpensive the place was, relatively speaking. The historical richness of the country came to life in Dubrovnik, when I walked along the walls of the old city and saw old roof tiles shattered during the war lying side by side with new roof tiles built to replace them – a poignant reminder of the constant presence of the past, but also an inspiring example of how tourism can help rebuild a place.

Croatia's beauty was obvious: the rocky coast and the shadowing cypresses, the wildflowers in bloom and not a person in sight.

And then it all came together for me on my last night in Dubrovnik, when I went out to dinner with a local tour guide and she told me about how her family had suffered during the war, how the entire country had suffered, but there was now new hope blooming in the land.

On reviewing these experiences, I realise that the historic part of the piece has more emotional resonance for me than the beautiful landscape. And so, I rearrange the segments. I start with the process, then move on to the beauty and the history, and end with my meal with the tour guide. I'll have to make sure I pay attention to the transitions between the sections, but the piece is already taking shape in my mind. I've figured out how to structure the middle, and now it's just a question of bringing the individual examples to vivid life.

QUESTION

Which of these factors does the writer consider most important when writing a travel piece about Croatia?

- A The amount of detail that is provided for each personal story.
- B The extent to which each experience described was personally moving.
- C The way that the story moves between history and the present day.
- D The way that the story links the distressing and rewarding experiences.

**PRINT READING QUESTION (LEVEL 3)
THE CORRECT ANSWER:**

**(B) THE EXTENT TO WHICH EACH EXPERIENCE
DESCRIBED WAS PERSONALLY MOVING.**

QUESTION LEVEL

Students at Proficiency Level 3 are capable of reading tasks of moderate complexity, such as locating multiple pieces of information, making links between different parts of a text, and relating it to familiar everyday knowledge. Tasks at this level require the reader to locate, and in some cases recognise the relationship between, several pieces of information that must meet multiple conditions. Interpretative tasks at this level require the reader to integrate several parts of a text in order to identify a main idea, understand a relationship, or construe the meaning of a word or phrase. They need to take into account many features in comparing, contrasting or categorising. The required information might not be prominent or there may be too much competing information, or there might be other obstacles in the text, such as ideas that are contrary to expectation or that are negatively worded. Reflective tasks at this level might require connections, comparisons, and explanations, or they might require the reader to evaluate a feature of the text. Some reflective tasks require readers to demonstrate a fine understanding of the text in relation to everyday knowledge. Other tasks do not require detailed text comprehension but require the reader to draw upon less common knowledge.

NATURE OF THE TASK

Interpret the main factor involved in organising an article

The situation is *educational*. The question belongs to the *instruction* text type category because it is the type of text that provides directions on what to do. The text presents directions for certain behaviours in order to complete a task (e.g. a recipe, a series of diagrams showing a procedure for giving first aid, and guidelines for operating digital software).

READING ASPECT

The aspect is *integrate and interpret – form a broad understanding* because the individual has to focus on relationships within the whole text.

SCORING

Full credit: B. The extent to which each experience described was personally moving.

No credit: Other responses or missing.

QUESTION LEVEL 4: LOST AT SEA**LOST AT SEA**

Dawn did not break slowly, as it does on land. The sky turned pale, the first stars disappeared, and I went on looking, first at my watch and then at the horizon. The contours of the sea began to appear. Twelve hours had passed, but it didn't seem possible. Night couldn't be as long as day. You have to have spent the night at sea, sitting in a life raft and looking at your watch, to know that the night is immeasurably longer than the day. But soon dawn begins to break, and then it's wearying to know it's another day.

That occurred to me on my first night in the raft. When dawn came, nothing else mattered. I thought neither of water nor of food. I didn't think of anything at all, until the wind turned warmer and the sea's surface grew smooth and golden. I hadn't slept a second all night, but at that moment it seemed as if I'd just awakened. When I stretched out in the raft my bones ached and my skin burned. But the day was brilliant and warm, and the murmur of the wind picking up gave me a new strength to continue waiting. And I felt profoundly composed in the life raft. For the first time in my twenty years of life, I was perfectly happy.

The raft continued to drift forward – how far it had gone during the night I couldn't calculate – but the horizon still looked exactly the same, as if I hadn't moved a centimetre. At seven o'clock I thought of the destroyer. It was breakfast time. I imagined my shipmates seated around the table eating apples. Then we would have eggs. Then meat. Then bread and coffee. My mouth filled with saliva and I could feel a slight twisting in my stomach. To take my mind off the idea of food, I submerged myself up to my neck in the bottom of the raft. The cool water on my sunburned back was soothing and made me feel stronger. I stayed submerged like that for a long time, asking myself why I had gone with Ramón Herrera to the stern deck instead of returning to my bunk to lie down. I reconstructed the tragedy minute by minute and I decided I had been stupid. There was really no reason I should have been one of the victims: I wasn't on watch, I wasn't required on deck. When I concluded that everything that had happened was due to bad luck, I felt anxious again. But looking at my watch calmed me down. The day was moving along quickly: it was eleven-thirty

QUESTION

How does the sailor try to cope with his experiences throughout the passage?

- A By staying alert.
- B By avoiding worry.
- C By remembering what happened.
- D By trying to forget the past.

**PRINT READING QUESTION (LEVEL 4)
THE CORRECT ANSWER IS:**

(B) BY AVOIDING WORRY.

QUESTION LEVEL

Students at Proficiency Level 4 are capable of difficult reading tasks such as locating embedded information, construing meaning from linguistic nuances and critically evaluating a text. Tasks at this level that involve retrieving information require the reader to locate and organise several pieces of embedded information. Some tasks at this level require interpreting the meaning of nuances in a section of text by taking into account the text as a whole. Other interpretative tasks require understanding and applying categories in an unfamiliar context. Reflective tasks at this level require readers to use formal or public knowledge to hypothesise about or critically evaluate a text. Readers must demonstrate an accurate understanding of long or complex texts whose content or form might be unfamiliar.

NATURE OF THE TASK

Identify a character's overall response to a situation

The situation is *personal*. The question belongs to the *narration* text type category because it is the type of text where the information refers to properties of objects in time. Narration typically answers questions relating to when, or in what sequence.

READING ASPECT

The aspect is *integrate and interpret – form a broad understanding* because the individual has to focus on relationships within the whole text.

SCORING

Full credit: B. By avoiding worry.

No credit: Other responses or missing.

QUESTION LEVEL 5: WELL-BEING IN THE UNITED STATES

In 2008, a survey investigated the well-being of people in the United States in relation to their age. The telephone survey involved more than 340,000 people, aged from 18 to 85. The figures below show some of the results.

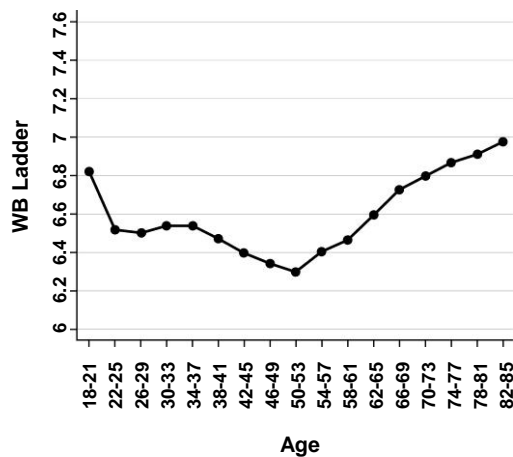

Figure 1: Global Well-being (overall life satisfaction)

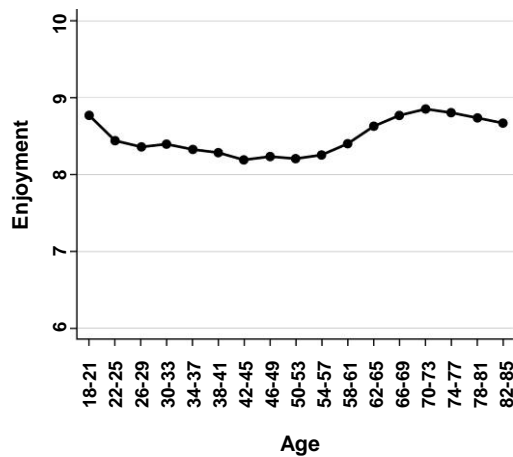

Figure 2: Results for Enjoyment (a component of hedonic well-being)

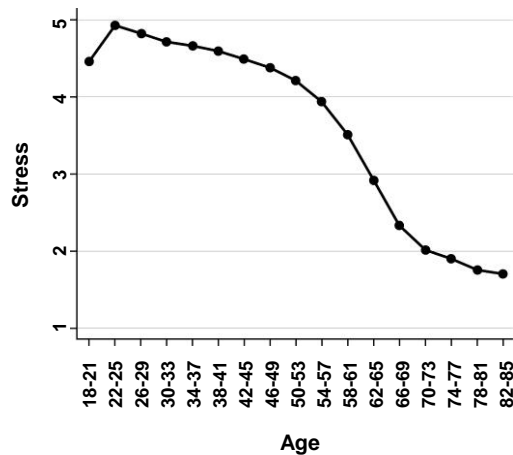

Figure 3: Results for Stress (a component of hedonic well-being)

GLOBAL WELL-BEING

Survey participants were asked to rank their overall life satisfaction on a 10-point scale. This became their “global well-being” score.

HEDONIC WELL-BEING

Survey participants were also asked six yes-or-no questions aimed at establishing their “hedonic wellbeing”, which is a person’s immediate experience of a psychological state. These questions asked whether participants had experienced particular feelings for a long period of time the previous day (enjoyment, happiness, stress, worry, anger, sadness). According to researchers, such answers are free from the revised memories or subjective judgements that the question about overall life satisfaction may encourage.

Information was also collected about participants’ gender, personal finances, health and other matters.

QUESTION

In order to get the information shown in Figure 3, which of these questions might the researchers have asked the participants during the telephone survey?

- A On a scale of 1 to 10, how much stress did you experience yesterday?
- B At what time of the day yesterday did you experience stress?
- C Did you experience stress for a large part of the day yesterday?
- D At what age did you experience most stress?

**PRINT READING QUESTION (LEVEL 5)
THE CORRECT ANSWER IS:**

**(C) DID YOU EXPERIENCE STRESS FOR A LARGE PART
OF THE DAY YESTERDAY?**

QUESTION LEVEL

Students at Proficiency Level 5 can handle texts that are unfamiliar in either form or content. They can find information in such texts, demonstrate detailed understanding, and infer which information is relevant to the task. They are also able to critically evaluate such texts and build hypotheses about them, drawing on specialised knowledge and accommodating concepts that might be contrary to expectations. An inspection of the kinds of tasks students at Level 5 are capable of suggests that those who get to this level and Level 6 can be regarded as potential “world class” knowledge workers of tomorrow.

NATURE OF THE TASK

Identify explicitly stated information reworked in a question format

The situation is *public*. The question belongs to the *exposition* text type category because it is the type of text in which the information is presented as composite concepts or mental constructs, or those elements into which concepts or mental constructs can be analysed.

READING ASPECT

The aspect is *integrate and interpret – develop an interpretation* because the individual has to focus on relationships between parts of the text.

SCORING

Full credit: C. Did you experience stress for a large part of the day yesterday?

No credit: Other responses or missing.

QUESTION LEVEL 6: WELL-BEING IN THE UNITED STATES

In 2008, a survey investigated the well-being of people in the United States in relation to their age. The telephone survey involved more than 340,000 people, aged from 18 to 85. The figures below show some of the results.

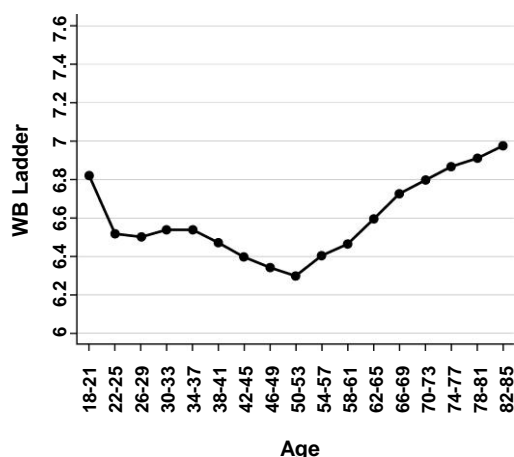

Figure 1: Global Well-being (overall life satisfaction)

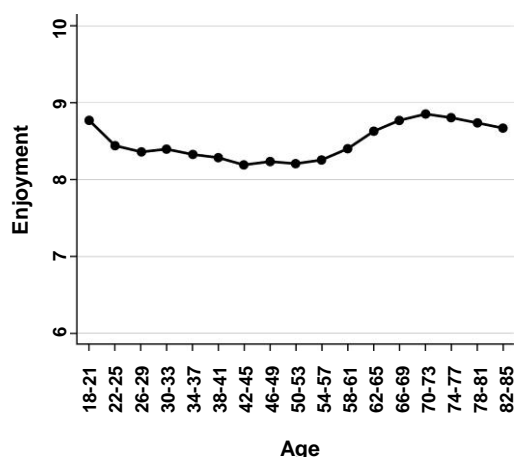

Figure 2: Results for Enjoyment (a component of hedonic well-being)

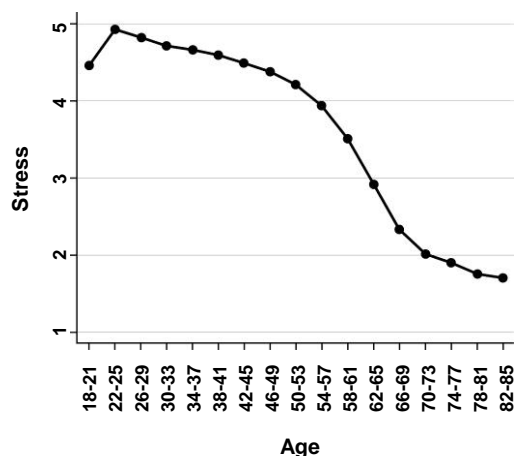

Figure 3: Results for Stress (a component of hedonic well-being)

GLOBAL WELL-BEING

Survey participants were asked to rank their overall life satisfaction on a 10-point scale. This became their “global well-being” score.

HEDONIC WELL-BEING

Survey participants were also asked six yes-or-no questions aimed at establishing their “hedonic wellbeing”, which is a person’s immediate experience of a psychological state. These questions asked whether participants had experienced particular feelings for a long period of time the previous day (enjoyment, happiness, stress, worry, anger, sadness). According to researchers, such answers are free from the revised memories or subjective judgements that the question about overall life satisfaction may encourage.

Information was also collected about participants’ gender, personal finances, health and other matters.

QUESTION



This research shows how satisfied different age groups are, but it can't say anything about **why** this is the case.

Is this a fair comment?

Click "Yes" or "No" and explain your answer.

Yes No

Type your answer here:

.....

**PRINT READING QUESTION (LEVEL 6)
THE CORRECT ANSWER:**

**ANSWERS OR IMPLIES NO, AND REFERS TO THE
PURPOSE OF COLLECTING ADDITIONAL PERSONAL
INFORMATION FROM THE PARTICIPANTS.**

QUESTION LEVEL

Students at Proficiency Level 6 are highly skilled readers. They can conduct fine-grained analyses of texts, which require detailed comprehension of both explicit information and unstated implications, and they can reflect on and evaluate what they read at a more general level. Students at this level have successfully completed most of the tasks presented to them in the reading assessment, demonstrating that they are capable of dealing with many different types of reading material. Hence, they are diversified readers who can assimilate information from unfamiliar content areas presented in atypical formats, as well as being able to engage with more familiar content with typical structures and text features. Another characteristic of the most highly developed readers is that they can overcome preconceptions in the face of new information, even when that information is contrary to expectations. Students at this level are capable of recognising what is provided in a text, both conspicuous and more subtle information, while being able to apply a critical perspective to it, drawing on sophisticated understanding beyond the text.

NATURE OF THE TASK

Use information from a report to evaluate a criticism of the report

The situation is *public*. The question belongs to the *exposition* text type category because it is the type of text in which the information is presented as composite concepts or mental constructs, or those elements into which concepts or mental constructs can be analysed.

READING ASPECT

The aspect is *integrate and interpret – develop an interpretation* because the individual has to focus on relationships between parts of the text.

SCORING

Full credit: Answers or implies No, and refers to the purpose of collecting additional personal information from the participants.

No credit: Answers or implies No without any explanation or with an implausible, irrelevant or vague explanation; Answers or implies Yes; Shows inaccurate comprehension of the material or gives an implausible or irrelevant answer; or missing.

QUESTION LEVEL 1: IRON-ON IMAGE

Josh designs images for t-shirts on his computer. He prints the images using special paper. The image is then ironed onto the t-shirt.

The final image on the t-shirt is a **mirror image** of the design on the computer.

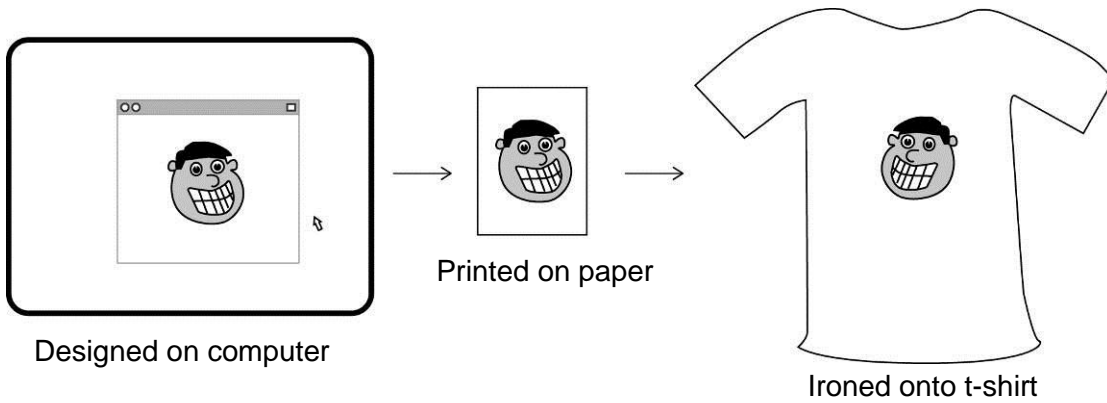

QUESTION

This picture shows a new design Josh printed onto paper.



How will the design appear on the **t-shirt**?

A

B

C

D

**MATHEMATICS QUESTION (LEVEL 1)
THE CORRECT ANSWER IS:****QUESTION LEVEL**

Students at Proficiency Level 1 can answer questions involving familiar contexts where all relevant information is present and the questions are clearly defined. They are able to identify information and to carry out routine procedures according to direct instructions in explicit situations. They can perform actions that are obvious and follow immediately from the given stimuli.

NATURE OF THE TASK

Identify the reflection of an abstract image

The context is *occupational*. The question belongs to the *space and shape* content category, which encompasses a wide range of phenomena that are encountered everywhere in our visual and physical world: patterns, properties of objects, positions and orientations, representations of objects, decoding and encoding of visual information, navigation and dynamic interaction with real shapes as well as with representations.

MATHEMATICAL PROCESS

The process is *employing mathematical concepts, facts, procedures and reasoning* because the individual has to apply mathematical concepts, facts, procedures, and reasoning to solve mathematically-formulated problems to obtain mathematical conclusions.

SCORING

Full credit: B. (graphic)

No credit: Other responses or missing.

QUESTION LEVEL 2: FREE TICKETS

A radio station has 10 free tickets to a concert to give away.

Each listener may send in **one** email requesting a ticket.

Emails are received from 1200 listeners.

Emails are then selected at random one at a time until all tickets are given away.

QUESTION

The first 9 tickets have been given away.

John's email has not been selected.

What is John's chance of winning the **last** ticket?

John's chance = 1 in

**MATHEMATICS QUESTION (LEVEL 2)
THE CORRECT ANSWER IS:****1191 OR WORKING THAT SHOWS $1 \div 1191$** **QUESTION LEVEL**

Students at Proficiency Level 2 can interpret and recognise situations in contexts that require no more than direct inference. They can extract relevant information from a single source and make use of a single representational mode. Students at this level can employ basic algorithms, formulae, procedures, or conventions. They are capable of direct reasoning and literal interpretations of the results. PISA considers Level 2 a baseline level of mathematics proficiency at which students begin to demonstrate the kind of skills that enable them to use mathematics in ways that are considered fundamental for their future development.

NATURE OF THE TASK

Calculate conditional probability of an event

The context is *societal*. The question belongs to the *uncertainty and data* content category, which includes recognising the place of variation in processes, having a sense of the quantification of that variation, acknowledging uncertainty and error in measurement, and knowing about chance.

MATHEMATICAL PROCESS

The process is *formulating situations mathematically* because the individual has to recognise and identify opportunities to use mathematics and then provide mathematical structure to a problem presented in some contextualised form.

SCORING

Full credit: 1191 or working that shows $1 \div 1191$

No credit: Other responses or missing.

QUESTION LEVEL 3: WHICH FORMULA?

Steph and Jawad run their own businesses.

Steph makes greeting cards and sells them at a market each Sunday.

Jawad is a gardener.



QUESTION

Jawad's total charge for a gardening job is:

- a fixed charge of 20 zeds plus
- an hourly charge of 30 zeds per hour.

Write a formula that shows how Jawad's total charge, C , relates to, h , the number of hours he spends on a job?

NOTE: PISA questions often refer to situations that take place in the fictional country of Zedland, where the Zed is the unit of currency.

Type your response here:

.....

MATHEMATICS QUESTION (LEVEL 3)
THE CORRECT ANSWER IS:

**AN EXPRESSION THAT SHOWS AN UNDERSTANDING
OF THE RELATIONSHIP BETWEEN TOTAL CHARGE,
FIXED CHARGE, HOURLY CHARGE AND HOURS
(E.G., $C = 30H + 20$; $C = 20 + H \times 30$)**

QUESTION LEVEL

Students at Proficiency Level 3 can execute clearly described procedures, including those that require sequential decisions. They can select and apply simple problem-solving strategies. Students at this level can interpret and use representations based on different information sources and reason directly from them. They can develop short communications reporting their interpretations, results and reasoning.

NATURE OF THE TASK

Create a correct formula in a context based on a linear relationship between fixed and variable costs

The context is *occupational*. The question belongs to the *change and relationships* content area, which involves understanding fundamental types of change and recognising when they occur in order to use suitable mathematical models to describe and predict change.

MATHEMATICAL PROCESS

The process is *formulating situations mathematically* because the individual has to recognise and identify opportunities to use mathematics and then provide mathematical structure to a problem presented in some contextualised form.

SCORING

Full credit: An expression that shows an understanding of the relationship between total charge, fixed charge, hourly charge and hours

Partial credit: An expression that shows an understanding of the relationship between total charge, hourly charge and hours [omits fixed charge]

No credit: Other responses or missing.

QUESTION LEVEL 4: AGE OF MOTHERS

This graph shows the percentage of births in Zedland for two years (1960 and 2000), according to the mother’s age at the time of birth.

For example, in 1960, 16% of the births were to mothers in the 30-34 age group.

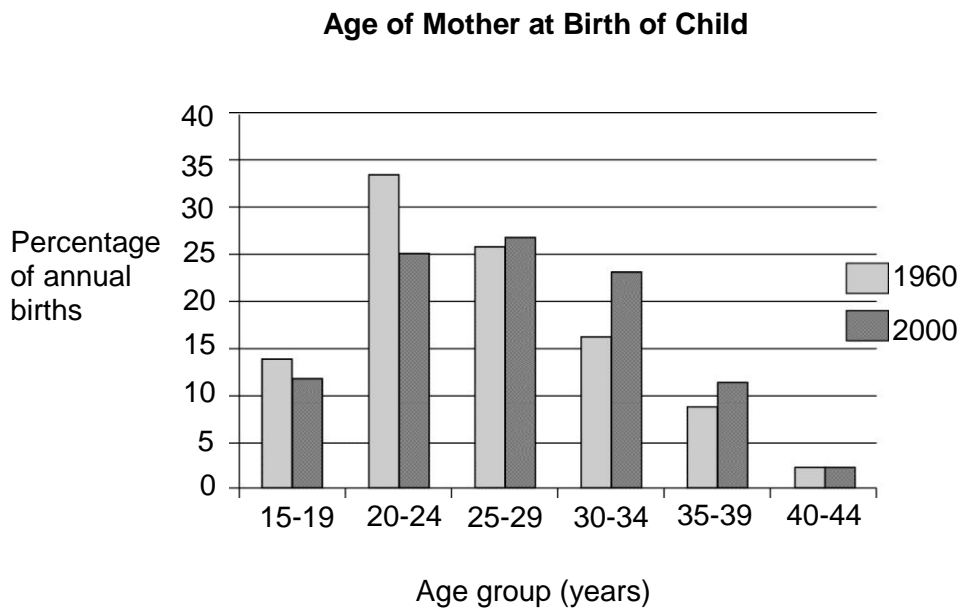

NOTE: PISA questions often refer to situations that take place in the fictional country of Zedland.

QUESTION

Is each of the following statements about the graph true or false?

Click “True” or “False” for each statement.

Statement	True or False?
Approximately one quarter of the births in 1960 were to mothers aged 25-29.	True / False
There were fewer mothers who gave birth aged 15-19 in 2000 than in 1960.	True / False
In 1960, the median age of mothers who gave birth was in the 20-24 age group.	True / False

**MATHEMATICS QUESTION (LEVEL 4)
THE CORRECT ANSWER IS:****TRUE, TRUE, FALSE IN THAT ORDER****QUESTION LEVEL**

Students at Proficiency Level 4 can work effectively with explicit models for complex, concrete situations that might involve constraints or call for making assumptions. They can select and integrate different representations, including symbolic ones, linking them directly to aspects of real-world situations. Students at this level can use well-developed skills and reason flexibly, with some insight, in these contexts. They can construct and communicate explanations and arguments based on their interpretations, arguments and actions.

NATURE OF THE TASK

Determine accuracy of statements about grouped data represented by comparative bar graph

The context is *societal*. The question belongs to the *uncertainty and data* content category, which includes recognising the place of variation in processes, having a sense of the quantification of that variation, acknowledging uncertainty and error in measurement, and knowing about chance.

MATHEMATICAL PROCESS

The process is *employing mathematical concepts, facts, procedures and reasoning* because the reader has to recognise and identify opportunities to use mathematics and then provide mathematical structure to a problem presented in some contextualised form.

SCORING

Full credit: Three correct responses: True, True, False in that order

No credit: Fewer than three correct responses or missing.

QUESTION LEVEL 5: SUN ROOM

The diagrams show the plans for a sun room. It will be built onto the wall of a house.

The four walls of the sunroom are square clear glass panels.

The roof is made using

- four clear glass panels, trapezium in shape, all the same size
- one tinted glass panel, half a regular octagon in shape.

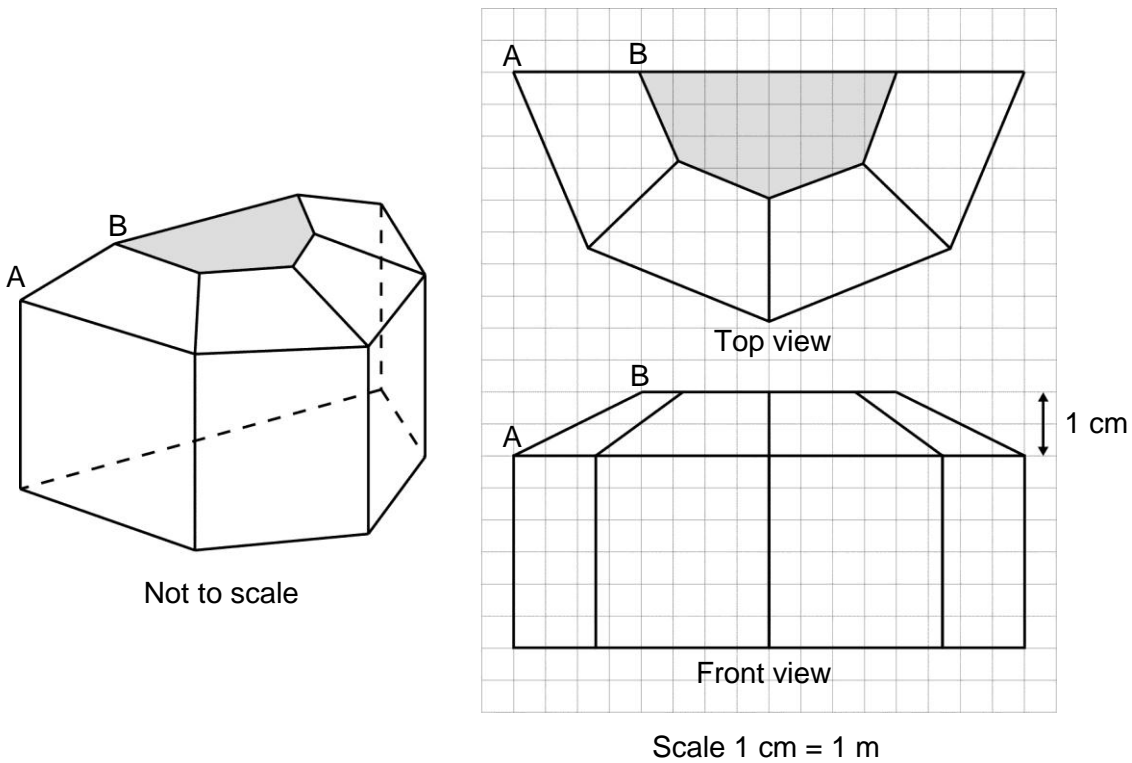

QUESTION

The edge AB of one of the roof panels is shown on the diagrams.

What is the actual length of AB?

..... metres

**MATHEMATICS QUESTION (LEVEL 5)
THE CORRECT ANSWER IS:****2.236 OR 2.24 OR 2.2 OR $\sqrt{5}$.****QUESTION LEVEL**

Students at Proficiency Level 5 can develop and work with models for complex situations, identifying constraints and specifying assumptions. They can select, compare, and evaluate appropriate problem solving strategies for dealing with complex problems related to these models. Students at this level can work strategically using broad, well-developed thinking and reasoning skills, appropriate linked representations, symbolic and formal characterisations, and insight pertaining to these situations. They can reflect on their actions and formulate and communicate their interpretations and reasoning.

NATURE OF THE TASK

Use information from scale drawings and Pythagoras' Theorem to show how an actual length is found

The context is *societal*. The question belongs to the *space and shape* content area, which encompasses a wide range of phenomena that are encountered everywhere in our visual and physical world: patterns, properties of objects, positions and orientations, representations of objects, decoding and encoding of visual information, navigation and dynamic interaction with real shapes as well as with representations.

MATHEMATICAL PROCESS

The process is *employing mathematical concepts, facts, procedures and reasoning* because the reader has to recognise and identify opportunities to use mathematics and then provide mathematical structure to a problem presented in some contextualised form.

SCORING

Full credit: 2.236 or 2.24 or 2.2 or $\sqrt{5}$

Partial credit: 2 [Uses scale correctly but not Pythagoras]

No credit: Other responses or missing.

QUESTION LEVEL 6: FILL A ROOM COMPETITION

To raise money for a school fete, a competition is held.

Students must guess the number of bags of plastic beads that would be needed to fill a classroom.

Each bag holds 100 litres of beads.

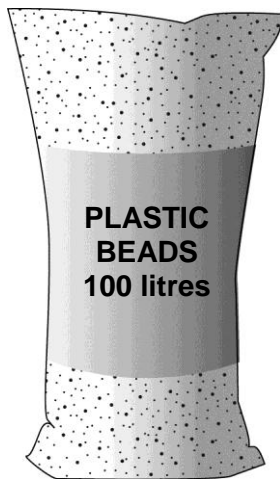

QUESTION

One kilolitre of beads fills one cubic metre.

Show by your working that the volume of one bag of beads is 0.1 cubic metres.

Type your answer here:

.....

**MATHEMATICS QUESTION (LEVEL 6)
THE CORRECT ANSWER:****SHOWS THAT 100 LITRES IS EQUIVALENT TO 0.1 M³.****QUESTION LEVEL**

Students at Proficiency Level 6 can conceptualise, generalise and utilise information based on their investigations and modelling of complex problems. They can link different information sources and representations and flexibly translate between them. Students at this level are capable of advanced mathematical thinking and reasoning. They can apply this insight and understanding along with a mastery of symbolic and formal mathematical operations and relationships to develop new approaches and strategies for attacking novel situations. Students at this level can formulate and precisely communicate their actions and reflections regarding their findings, interpretations, arguments, and the appropriateness of these to the original situations.

NATURE OF THE TASK

Use metric information about volume and capacity to show that a quantity of litres is equivalent to a fraction of a cubic metre

The context is *personal*. The question belongs to the *quantity* content area, which involves understanding measurements, counts, magnitudes, units, indicators, relative size, and numerical trends and patterns. Aspects of quantitative reasoning – such as number sense, multiple representations of numbers, elegance in computation, mental calculation, estimation and assessment of reasonableness of results – are the essence of mathematical literacy relative to quantity.

MATHEMATICAL PROCESS

The process is *employing mathematical concepts, facts, procedures and reasoning* because the individual has to apply mathematical concepts, facts, procedures, and reasoning to solve mathematically-formulated problems to obtain mathematical conclusions.

SCORING

Full credit: Working shows that 100 litres is equivalent to 0.1 m³.

No credit: Other responses or missing.

QUESTION LEVEL 1: REVERSE OSMOSIS

One way of producing drinking water from seawater is by reverse osmosis.

Reverse osmosis is a type of filtration.

Seawater is pushed through a semi-permeable membrane. Pressure is applied to the seawater. Semi-permeable means salt is trapped on one side of the membrane, but water can pass through.

The trapped salts form a 'seawater concentrate' on one side of the membrane.

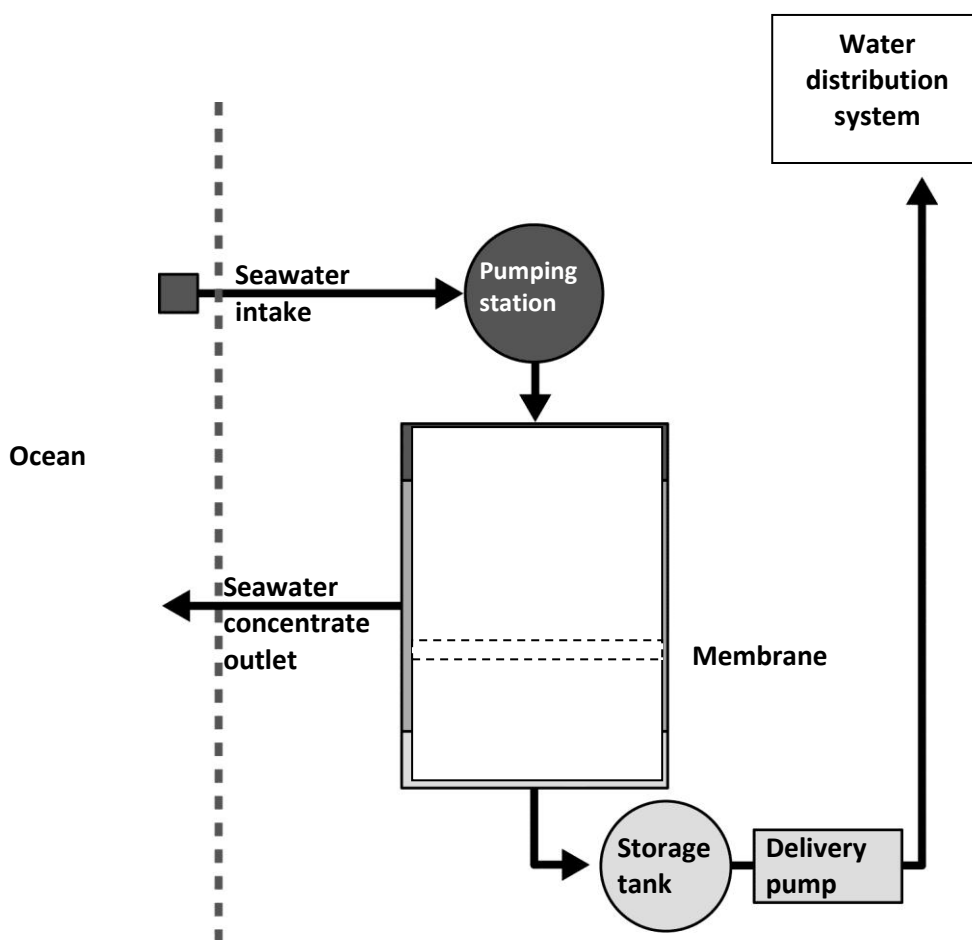

Seawater reverse osmosis desalination process

QUESTION

Where do the trapped salts go?

E ocean

- F storage tank
- G delivery pipeline
- H water distribution system

SCIENCE QUESTION (LEVEL 1)
THE CORRECT ANSWER IS:

(A) OCEAN.

QUESTION LEVEL

At Level 1, students have such a limited scientific knowledge that it can only be applied to a few, familiar situations. They can present scientific explanations that are obvious and follow explicitly from given evidence.

NATURE OF THE TASK

Access scientific information and produce a conclusion based on scientific evidence

The setting is *social*. The question belongs to the *knowledge about science – scientific explanations* knowledge category.

SCIENCE COMPETENCY

The competency is *using scientific evidence* because the individual has to access scientific information and produce arguments and conclusions based on scientific evidence. The required response can involve knowledge about science or knowledge of science or both.

SCORING

Full credit: A. ocean

No credit: Other responses or missing.

QUESTION LEVEL 2: REVERSE OSMOSIS

One way of producing drinking water from seawater is by reverse osmosis.

Reverse osmosis is a type of filtration.

Seawater is pushed through a semi-permeable membrane. Pressure is applied to the seawater. Semi-permeable means salt is trapped on one side of the membrane, but water can pass through.

The trapped salts form a 'seawater concentrate' on one side of the membrane.

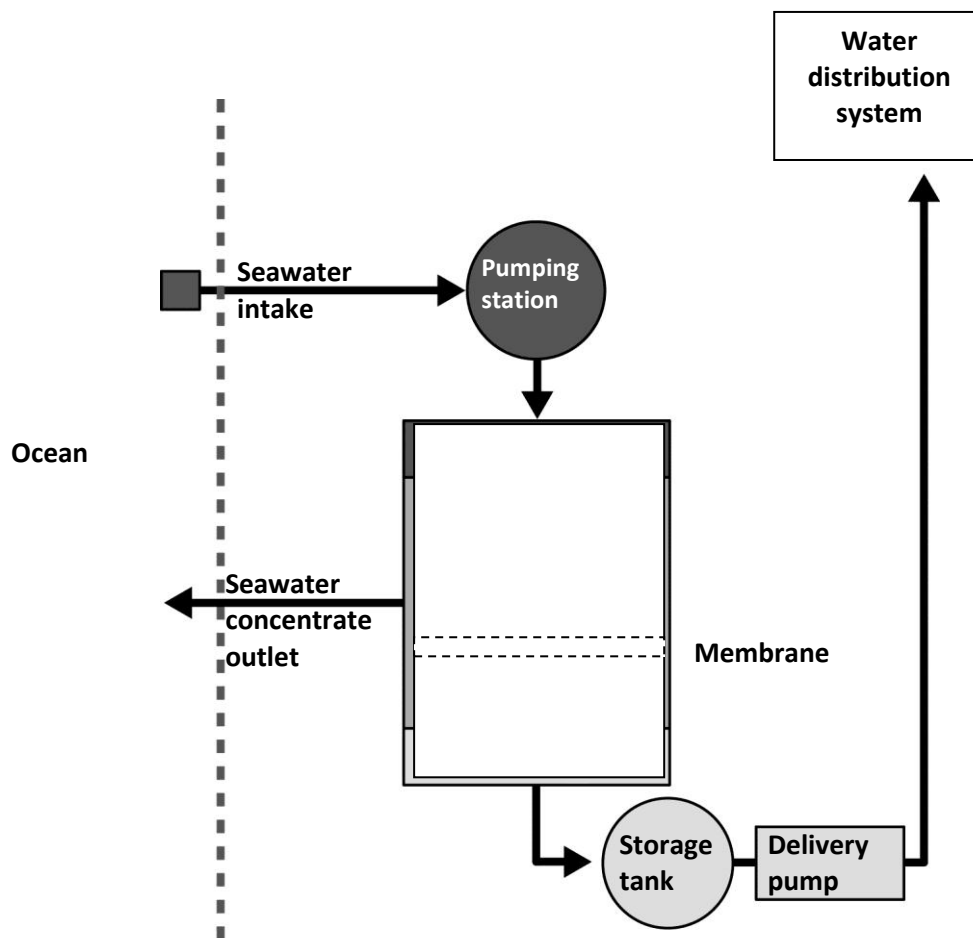

Seawater reverse osmosis desalination process

QUESTION

What will determine whether a particle is able to pass through the membrane?

- A particle size
- B particle mass
- C number of particles
- D charge on the particle

**SCIENCE QUESTION (LEVEL 2)
THE CORRECT ANSWER IS:****(A) PARTICLE SIZE.****QUESTION LEVEL**

At Level 2, students have adequate scientific knowledge to provide possible explanations in familiar contexts or draw conclusions based on simple investigations. They are capable of direct reasoning and making literal interpretations of the results of scientific inquiry or technological problem solving.

NATURE OF THE TASK

Use knowledge of science where a correct response requires an explanation of an observed scientific phenomenon

The situation is *social*. The question belongs to the *knowledge of science – physical systems* knowledge category.

SCIENCE COMPETENCY

The competency is *explaining phenomena scientifically* because it requires the reader to apply appropriate knowledge of science in a given situation. The competency includes describing or interpreting phenomena and predicting changes, and may involve recognising or identifying appropriate descriptions, explanations, and predictions.

SCORING

Full credit: A. particle size

No credit: Other responses or missing.

QUESTION LEVEL 3: CHOLERA

Cholera is a disease caused by bacteria. The symptoms are severe diarrhoea and vomiting.

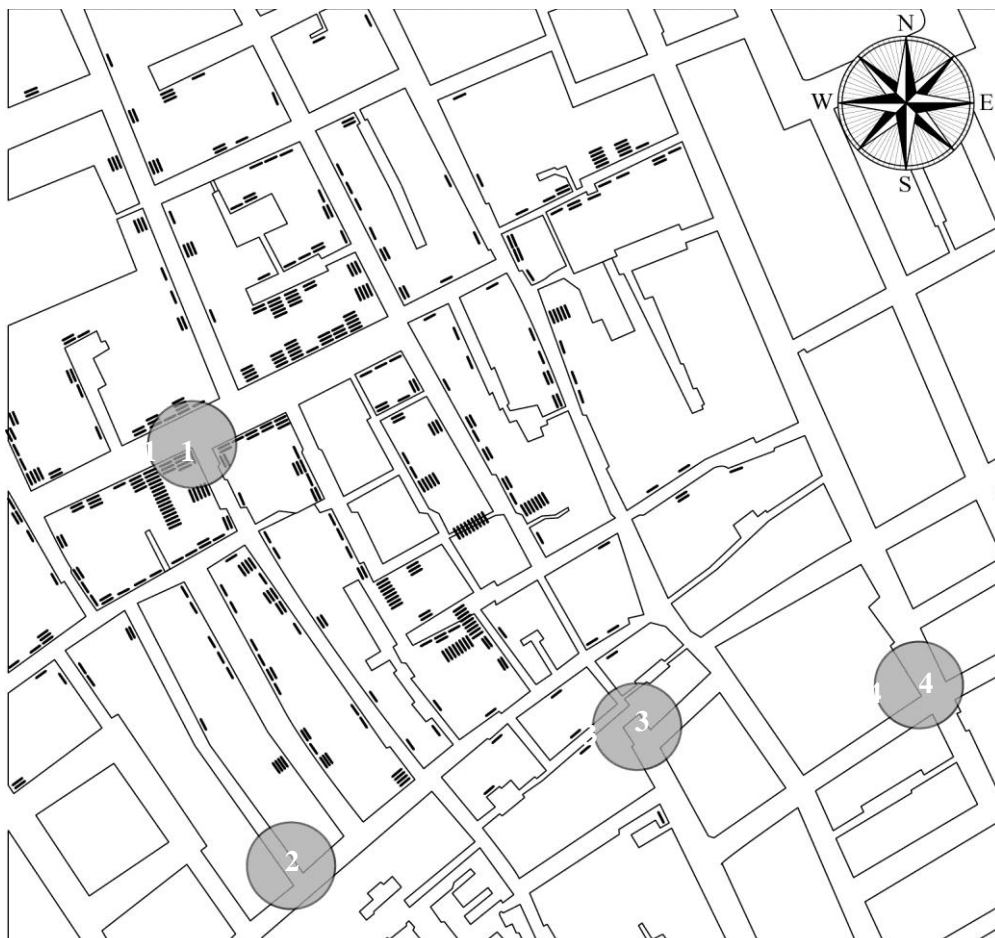

In August of 1854, there was a cholera epidemic in London. At the time it was assumed that cholera was airborne and caused by 'bad air'. John Snow, a British doctor didn't believe this theory.

Snow studied the pattern of deaths from the disease. He plotted a map of the affected area, marking the location of every person that died from cholera.



John Snow's map of London 1854 showing water pumps and places where people died of cholera.

KEY

-  **Water Pump**
-  **Deceased person**

QUESTION

What further research could John Snow have done to help find out how cholera spread?

Click “Yes” or “No” for the statements about further research.

Would this research have helped John Snow find out how cholera spread?	Yes or No?
Ask relatives of those that died which pump they collected their water from.	Yes / No
Find out who the cholera victims came into contact with just before they became ill.	Yes / No
Find out the direction the wind was blowing before the cholera outbreak.	Yes / No

**SCIENCE QUESTION (LEVEL 3)
THE CORRECT ANSWER IS:****YES, YES, YES IN THAT ORDER.****QUESTION LEVEL**

At Level 3, students can identify clearly described scientific issues in a range of contexts. They can select facts and knowledge to explain phenomena and apply simple models or inquiry strategies. Students at this level can interpret and use scientific concepts from different disciplines and can apply them directly. They can develop short statements using facts and make decisions based on scientific knowledge.

NATURE OF THE TASK

Recognise questions that it would be possible to investigate scientifically

The situation is *personal*. The question belongs to the *knowledge about science – scientific enquiry* knowledge category.

SCIENCE COMPETENCY

The competency is *identifying scientific issues* because the reader has to recognise questions that it would be possible to investigate scientifically in a given situation and identify keywords to search for scientific information on a given topic.

SCORING

Full credit: All three correct: Yes, Yes, Yes in that order.

Partial credit: Any two of the three correct.

No credit: Other responses or missing.

QUESTION LEVEL 4: HYDROPONICS

Hydroponics is a way of growing plants without soil. The plants grow in an insoluble porous material, e.g. sand, which is regularly soaked with water.

A simple hydroponics system is shown below.

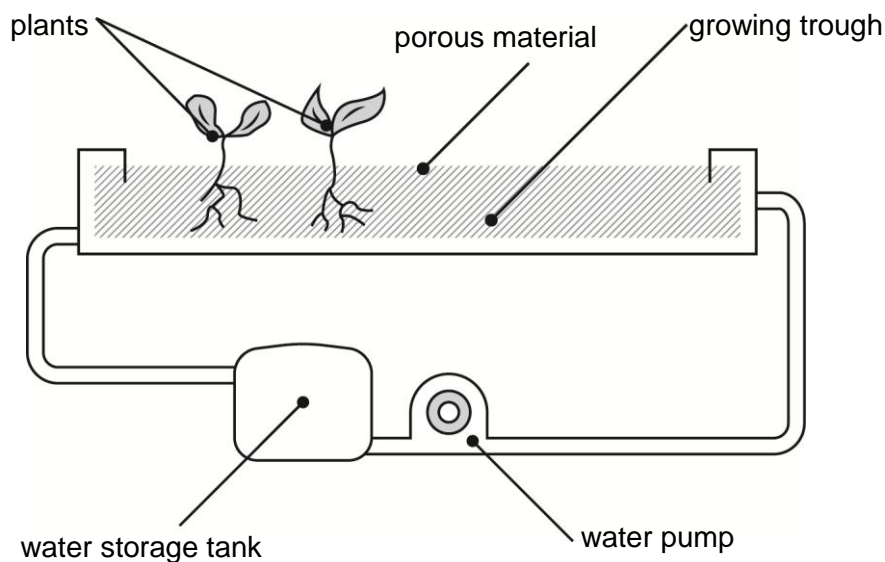

Simple HYDROPONICS system

Water is pumped through the system four to six times a day depending on plant type. Once the pumping stops, any excess water drains away and collects in the water storage tank.

QUESTION

Studies have shown that plants grown hydroponically use less water than plants grown in soil.

A key reason for this lies in the design of hydroponics systems.

What feature of the hydroponics system saves water compared to plants grown in soil?

- E The porous material holds the water in the growing trough.
- F Because water is not present all the time there is less evaporation.
- G Plants watered at regular intervals absorb less water.
- H Water flow over the roots cools the plant, so the plant uses less water.

**SCIENCE QUESTION (LEVEL 4)
THE CORRECT ANSWER IS:**

**(B) BECAUSE WATER IS NOT PRESENT ALL THE TIME
THERE IS LESS EVAPORATION.**

QUESTION LEVEL

At Level 4, students can work effectively with situations and issues that may involve explicit phenomena requiring them to make inferences about the role of science or technology. They can select and integrate explanations from different disciplines of science or technology and link those explanations directly to aspects of life situations. Students at this level can reflect on their actions and they can communicate decisions using scientific knowledge and evidence.

NATURE OF THE TASK

Access scientific information and produce a conclusion based on scientific evidence

The situation is *social*. The question belongs to the *knowledge about science – scientific explanations* knowledge category.

SCIENCE COMPETENCY

The competency is *using scientific evidence* because the individual has to access scientific information and produce arguments and conclusions based on scientific evidence. The required response can involve knowledge about science or knowledge of science or both.

SCORING

Full credit: B Because water is not present all the time there is less evaporation.

No credit: Other responses or missing.

QUESTION LEVEL 5: FLOATING

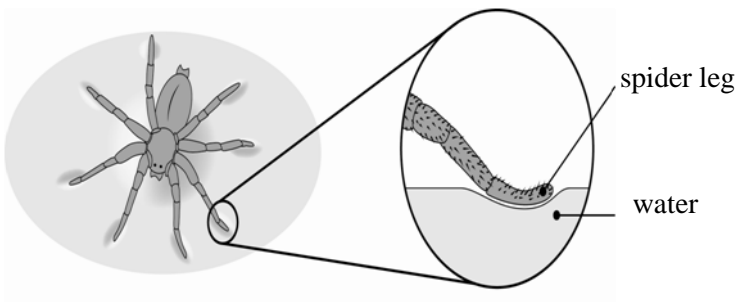

Spider or insect walking on water



Metal paperclip floating on water in a glass

QUESTION

Look at the pictures of the spider and the metal paper clip. What is the reason that both the spider and the paper clip can stay on top of the water?

Type your answer here:

**SCIENCE QUESTION (LEVEL 5)
THE CORRECT ANSWER:****MENTIONS THE SURFACE TENSION OF THE WATER
AND/OR EXPRESSES THE IDEA OF THE WEIGHT OF
THE OBJECT BEING SPREAD OVER A LARGE AREA.****QUESTION LEVEL**

At Level 5, students can identify the scientific components of many complex life situations, apply both scientific concepts and knowledge about science to these situations, and can compare, select and evaluate appropriate scientific evidence for responding to life situations. Students at this level can use well-developed inquiry abilities, link knowledge appropriately and bring critical insights to situations. They can construct explanations based on evidence and arguments based on their critical analysis.

NATURE OF THE TASK

Use knowledge of science where a correct response requires an explanation of an observed scientific phenomenon

The situation is *personal*. The question belongs to the *knowledge of science – physical systems* knowledge category.

SCIENCE COMPETENCY

The competency is *explaining phenomena scientifically* because it requires the reader to apply appropriate knowledge of science in a given situation. The competency includes describing or interpreting phenomena and predicting changes, and may involve recognising or identifying appropriate descriptions, explanations, and predictions.

SCORING

Full credit: Mentions the surface tension of the water and/or expresses the idea of the weight of the object being spread over a large area.

No credit: Responses that do not meet the “full credit” criteria or missing.

QUESTION LEVEL 6: UNDERGROUND COOLING

Most underground train systems have a problem of high temperatures within sections of their tunnels. For example, the London underground has several sections of rail line where the tunnel temperature can be above 40 °C.

The problem has become worse over the past 100 years as soil around the tunnels has gradually warmed.

QUESTION

Which of these heat sources could have contributed to warming soil around the tunnels deep underground?

Click “Yes” or “No” in each case.

Heat source	Does this heat source warm soil around the tunnels?
Heat from the sun.	Yes / No
Heat released from the trains brakes.	Yes / No
Heat from the train engines.	Yes / No
Heat from passengers' bodies.	Yes / No

**SCIENCE QUESTION (LEVEL 6)
THE CORRECT ANSWER IS:****NO, YES, YES, YES IN THAT ORDER****QUESTION LEVEL**

At Level 6, students can consistently identify, explain and apply scientific knowledge and knowledge about science in a variety of complex life situations. They can link different information sources and explanations and use evidence from those sources to justify decisions. They clearly and consistently demonstrate advanced scientific thinking and reasoning, and they use their scientific understanding in support of solutions to unfamiliar scientific and technological situations. Students at this level can use scientific knowledge and develop arguments in support of recommendations and decisions that centre on personal, social or global situations.

NATURE OF THE TASK

Use knowledge of science where a correct response requires an explanation of an observed scientific phenomenon

The situation is *social*. The question belongs to the *knowledge of science – physical systems* knowledge category.

SCIENCE COMPETENCY

The competency is *explaining phenomena scientifically* because it requires the reader to apply appropriate knowledge of science in a given situation. The competency includes describing or interpreting phenomena and predicting changes, and may involve recognising or identifying appropriate descriptions, explanations, and predictions.

SCORING

Full credit: All four correct: No, Yes, Yes, Yes in that order.

No credit: Other responses or missing.